

Bandstrap Adaptors

BND Series

Part Numbering

Bandstrap adaptors feature a corrosion-resistant steel band to terminate the cable screen. The resulting 360° termination creates an effective electrical connection, providing screen continuity between braid and adaptor. The terminated cable can then be protected and sealed using a heat-shrinkable moulded part, providing strain relief to the cable.

Using the part numbering elements below construct your part number, or contact us for details.

BND18 Straight adaptor family
Code 18 MIL-C-5015 (MS3100)

BND21 Straight adaptor family
Code 21 MIL-C-26482 Series I

BND40 Straight adaptor family
Code 40 MIL-C-38999 Series III & IV.

BND41 Straight adaptor family
Code 41 MIL-C-38999 Series I & II.

BND54 Straight adaptor family
Code 54 MIL-C-26482 Series II;
 MIL-C-5015 (MS3400)

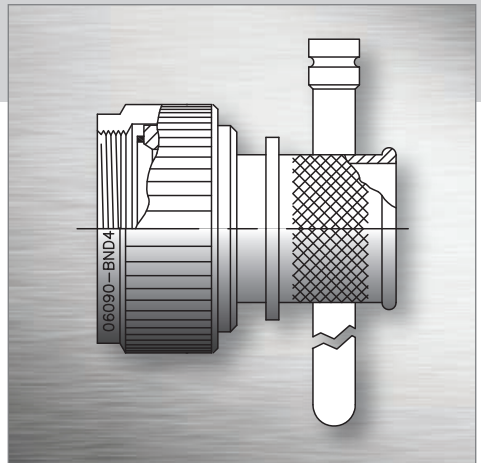

Selection Table

Ord. No.	Shell Size		Entry* Size	Entry Ø mm
	Ind. Ref.	Mil. Ref.		
08	9	A	04	6.35
10	11	B	07	11.12
12	12	C	09	14.30
14	15	D	10	15.88
16	17	E	12	19.05
18	19	F	14	22.23
20	21	G	16	25.40
22	23	H	18	28.58
24	25	J	20	31.10

Entry Ø sizes are nominal (based on those for the code 40 adaptor family), actual size may differ subject to adaptor family designation selected. * Denotes the maximum entry size permissible for given shell.

Bandstrap tool available **TIE-DEX-II-TOOL**, for all adaptor options available, please contact us.

The above adaptor family designations are for the most common applications, for others not listed here please contact us.

BND40 A Z 00 - 16 10 A

PART NUMBER EXAMPLE

Band Code: B European; or A Americas & Asia

Entry Size: See table above or contact us

Order Number Ref: See selection table above

Angle: 00 = straight; 45 = 45°; 90 = 90°

Finish Code: See earlier in this section

Material Code: See earlier in this section

Adaptor Family designation: See this page

Bandstrap Bands

BND Series

Part Numbering



The BND Bandstrap clamping strap is used throughout industry for terminating screens onto connectors and adaptors, offering;

- Low profile design
- Light weight construction
- Space reduction
- Ease of installation

Also available supplied in a pre-coiled form, please contact us for more information.

Supplied with the 'Bandstrap Adaptor on the previous page as part of the assembly, but also available separately as described on this page.

BND Band Strap Series - One Step

Part Number	Dimensions					Pre-Coiled
	Entry Sizes	A Nom.	B Nom.	C Nom.	E Nom.	Diameter
BND-0812S	03 to 14	206.3	5.0	3.2	1.3	21.8
BND-1425S	04 to 24	362.1	8.9	6.4	3.3	44.5
BND-1825S	26 to 34	457.2				63.5

All dimensions in millimetres.

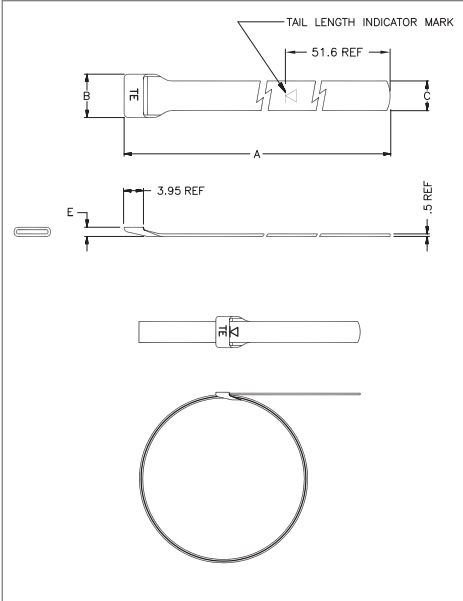

Notes;

- The band straps are constructed from 300 series passivated corrosion resisting steel.
- Recommended installation tools:
BND-0812X: **TIE-DEX-II-A30199**
BND-1425X, BND-1825X: **TIE-DEX-II-A40199**